

# Thesis Proposal

## Hakuna Resort

Swift Water, Pennsylvania



Image Courtesy of LMN Development LLC

Young Jeon

Structural Option

Advisor: Heather Sustersic

January 16<sup>th</sup> 2014

# Table of Contents

---

Thesis Proposal .....	1
Table of Contents .....	2
Executive summary .....	3
Purpose and Scope .....	4
Building Background Description .....	4
Structural System .....	6
Brief Description of Structural System .....	6
Foundation .....	6
Floor Systems .....	8
Lateral Load Resisting Elements .....	9
Framing System .....	11
Typical Bay .....	11
Columns .....	13
Roofing System .....	14
Joint Details .....	14
Problem Statement .....	16
Proposed Solution .....	16
Breadth Studies .....	16
Architecture .....	16
Construction Management .....	16
Solution Method .....	17
Tasks and Tools .....	18
Timetable .....	19
Conclusion .....	20

## Executive summary

---

Hakuna Resort is a jungle/safari theme hotel that includes a 217,703 square feet indoor water park as well as outdoor pool. The other side of the resort is convention centers which provides multiple meeting spaces. Divided into three distinctive spaces, the hotel is in between the indoor water park and convention space. These spaces are connected with expansion joints, therefore, can be looked at as three separate buildings.

The hotel building has total of eight stories above ground with total height of 101'-5" to the top of roof excluding the basement. With each floor having approximately 45,000 SF, the hotel portion of the resort has 395,938 SF by itself. The scope of this thesis project is limited to the hotel portion of the site; however, future assignment may incorporate an impactful design of hotel to improve cohesiveness of adjacent buildings.

The proposed thesis will include an investigation of an alternate lateral resisting system, the staggered steel truss system. The existing structure contains an extraordinary number of load bearing masonry shear walls in a non-seismic zone, which raises a question about the efficiency and necessity of the shear walls the structure has. With the repetitive floor layout of a residential hotel building, staggered truss was chosen to take the advantage of layout and minimize the design conflicts. To compare the existing lateral system and the alternate system, staggered truss system will be investigated and designed.

During this redesign process, other breadths will require careful consideration. The floor plan of lower floor of hotel which uses steel moment frames for lobby spaces may need readjustment with staggered truss system implementation. As an architectural breadth study, redesign of floor layout of lower levels and change in façade design will be investigated.

With the change in lateral resisting system material, difference in cost of alternate system and scheduling of different sequencing method need to be investigated as well. Therefore, cost analysis and scheduling will be studied and compared to the existing structure as a construction management breadth topic.

## Purpose and Scope

---

The purpose of this proposal is to describe existing structural condition, state the problem of overly rigid design due to the number of load bearing masonry shear walls and redesign existing lateral system to staggered steel truss system for hotel structure of Hakuna Resort at Swiftwater, PA. This proposal also includes two breadth topics that will be examined along with the alternate lateral system design, architectural and construction management.

## Building Background Description

---

Hakuna Resort is a jungle theme resort which includes both indoor waterpark and outdoor pool as well as convention centers and a luxury hotel space. The indoor waterpark, located north-west of the hotel, has a square footage of 143,798 SF in first floor and 73,905 SF on the second. As can be seen in figure 1, the convention center is located the opposite, south-east side of the hotel. With basement space of 18,802 SF, the convention center has first floor space of 92,668 SF. The biggest space, however, is the hotel with a total of 394,938 SF distributed throughout eight stories and a basement.

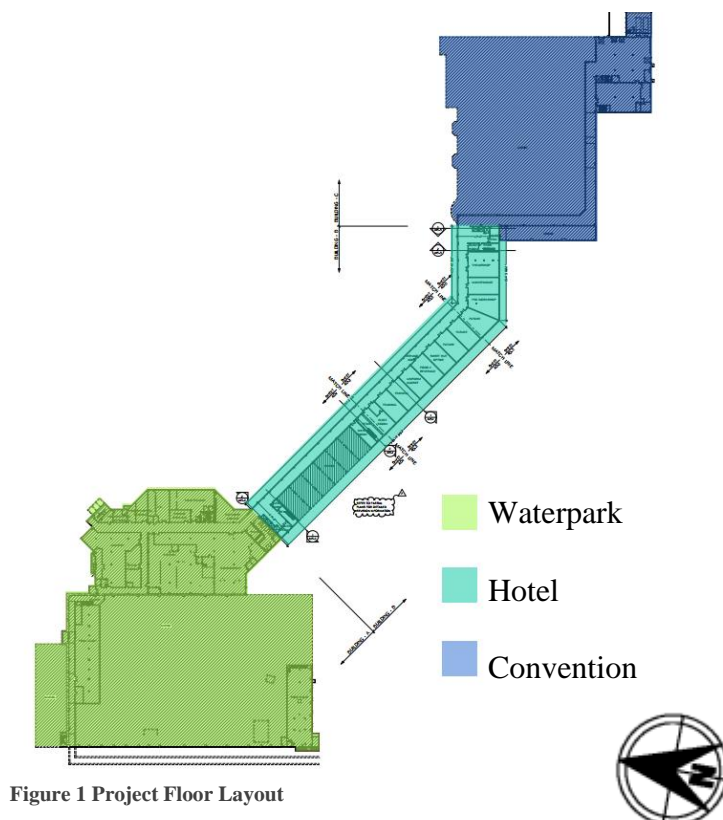

Construction began in March 2014. Hakuna Resort is scheduled to be completed and be open to public in summer of 2015. The project is also looking ahead for potential of three additions in the future (figure 2). The hotel, the tallest part of the project, is 101'-5" tall and has the most visual impact when confronted to the site.

The façade of the hotel building has color tone of brown, red, and grey to give earth-like feeling. Custom ancient stone architectural finishes, applied at the corners of the building, will keep the consistency of tribal jungle theme façade finishes. Also little more distinctive color finishes will be used at the top of hotel façade to give tribal character to the building. The interior designs are also jungle theme. Most of the furniture in hotel has bark surface finishes.

The floor plan layout is very simple in the hotel building. Most of the hotel rooms are identical in plan, repeated in a regular array at each floor level. The rooms facing southern side of building has balconies and northern side does not. Also, the rooms at the angled middle corner section and all rooms in the top floor have bigger suites.

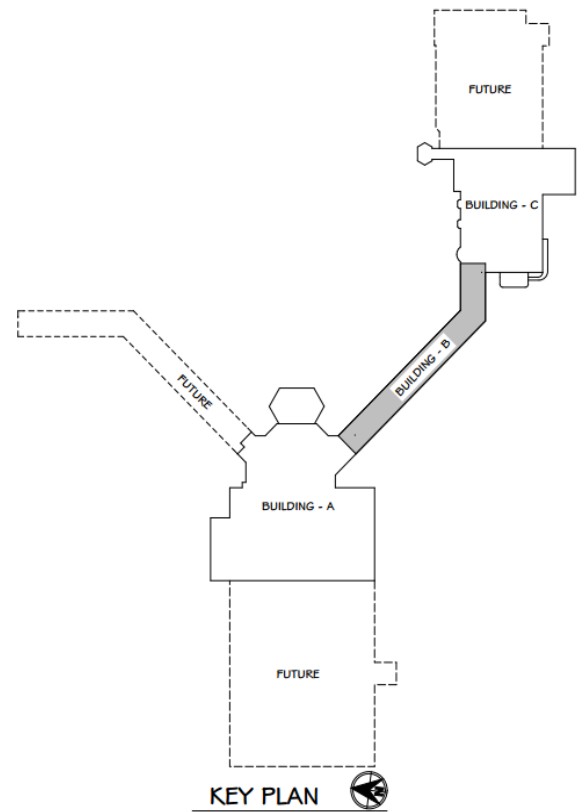

Figure 2 Project Future Additions



Figure 3 Hotel Building Rendering (looking from south)



# Structural System

---

## Brief Description of Structural System

Hakuna Resort is composed with three major components: indoor waterpark, hotel, and convention center. These components are connected by expansion joints, which allows each section to be considered as separate independent buildings. As stated before, only the hotel building will be described in this report due to its size. The main structural system used in this building is masonry shear walls and precast planks. There are also concrete piers, spread and strip footings, walls and masonry walls in the foundation and steel framing system in areas that require more flexible open spaces. The roof system is also precast hollow core planks.

## Foundation

The foundation of Hakuna Resort has spread and strip footings or varying sizes to support concrete columns, exterior walls, steel columns and concrete shear walls. According to the geotechnical report done by Pennoni Associates Inc., “spread footing foundations is feasible in dense natural soils, weathered rock or compacted load-bearing fill.” Both spread and strip footings have allowable bearing pressure of 4,000 and 6,000 psi with varying steel reinforcements.

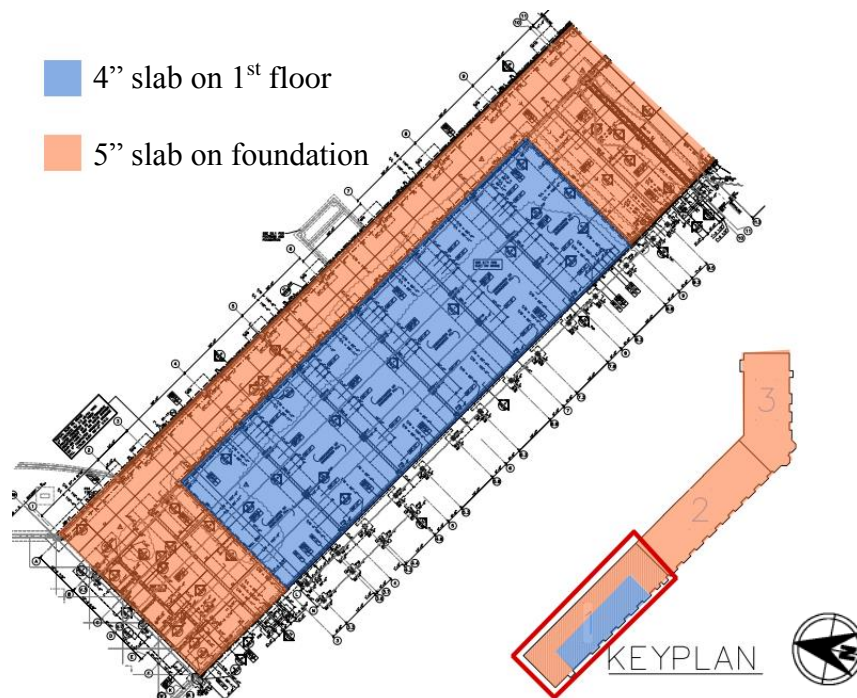

Figure 4 Partial Foundation Plan (S0.1)

For floor slabs, the geotechnical report approved using slab on grade with the usage of 4 inches thick layer of granular, free draining aggregate base course directly below the bottom of the slabs to provide a uniform bearing surface and improve overall slab performance. Figure 4 illustrates areas where 4” or 5” slab on grade is used.

A typical section of strip footings supporting the 1’ wide concrete shear walls is shown in figure 5. Because these footings are supporting the lateral resisting system, their thickness range from 2’ to 3’-6” whereas the strip footings of exterior walls are below 2’. The width of footings for

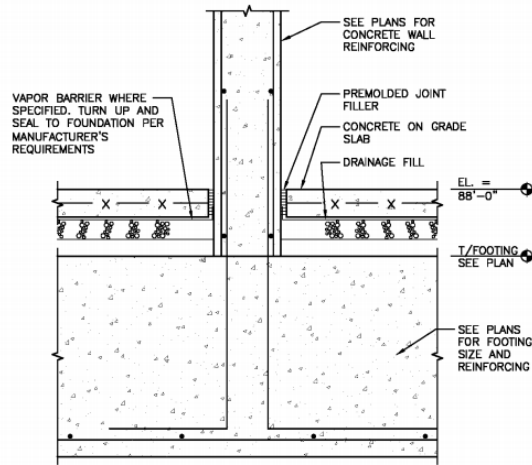

Figure 5 Concrete Wall Footing Section (S12.01, Drawing 14)

shear walls are also 12’-6” wide compared to exterior wall strip footing width, 2’-6”. Similarly, the spread footings supporting concrete columns and steel columns are shown below in figure 6 and 7.

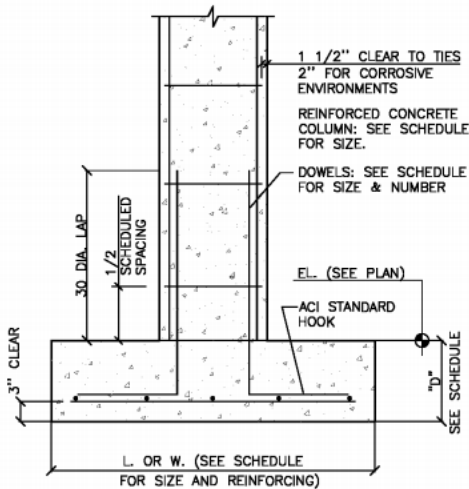
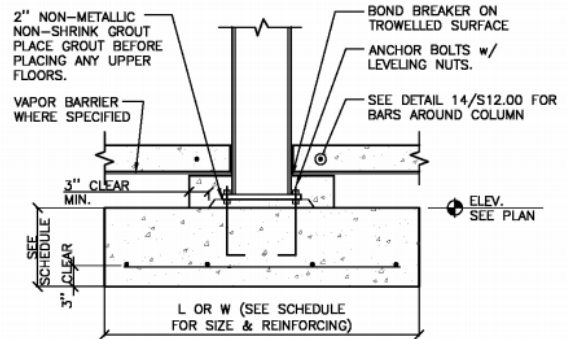

Figure 7 Typical Concrete Column Footing (S12.00 Drawing 10)



- ADJUST ANCHOR BOLT LENGTH TO MAINTAIN 3" MIN. BOTTOM COVERAGE
- WHERE BASE PLATES ARE NOT LARGE ENOUGH TO PLACE ANCHOR BOLTS OUTSIDE OF COLUMN FLANGES, PLACE ANCHOR BOLTS INSIDE. STEEL SUPPLIER TO DETAIL AND SUBMIT FOR APPROVAL.
- TURN UP AND SEAL VAPOR BARRIER AROUND COLUMNS PER MANUFACTURER'S DETAILS FOR PENETRATION.

Figure 6 Steel Column on Footing (S12.00 Drawing 16)

## Floor Systems

Hakuna Resort’s main floor system is prestressed precast hollow core planks. The hotel is a very narrow rectangular building with slight turn at the south-east end. The north-west side is about 501’-6” by 69’ and south-east is 151’-6” by 69’. Having precast planks spanning long direction allowed usage of load bearing walls in the other direction. This is a very effective choice of system while utilizing the architectural layout of hotel. Because the floor layout is repetitive with identical hotel rooms next to one another, putting loadbearing walls in between the rooms to support the precast planks is efficient approach.

There are two different thickness of precast planks. As shown in figure 8, there are 10” and 12” thick precast planks. 10” thick planks have six prestressed strands and are used throughout the building typically spanning 28’. The 12” thick planks, which also uses six strands, are only placed at the 45° corner highlighted in orange in figure 8 below. At this location, bigger suites that have maximum span of 40’ were designed. The balcony is also precast but solid plank that is 1’-½” thick which is supported by 1’ x 1’ precast columns at each exterior corner.

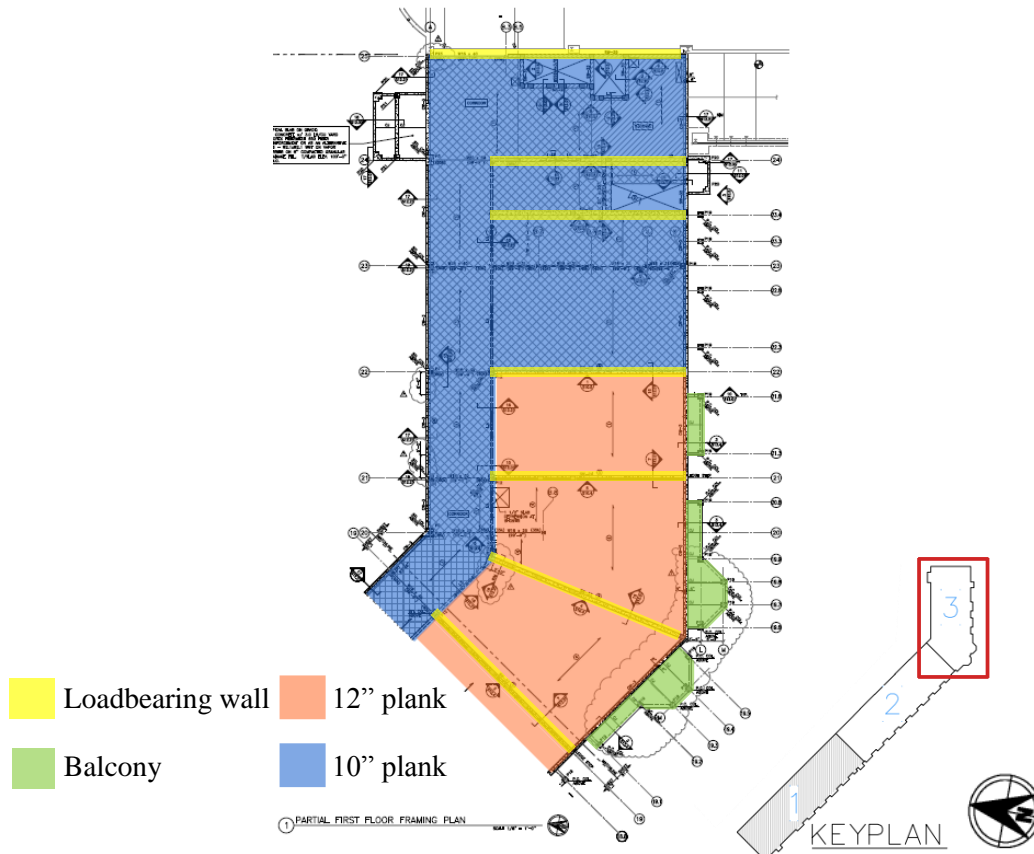

Figure 8 Partial First Floor Plan (S1.3)



## Lateral Load Resisting Elements

The main lateral force resisting system for Hakuna Resort consists of solid grouted 12” thick masonry walls. These concrete masonry units are structured to have masonry piers at each ends and sometimes in the middle as well instead of steel columns. The masonry pier schedule can be found in figure 10. The blocks have F'm of 2000 psi which requires a net area compressive strength of 2800 psi and grouted with 3000 psi grout. The typical layout of masonry shear walls can be found in figure 9.

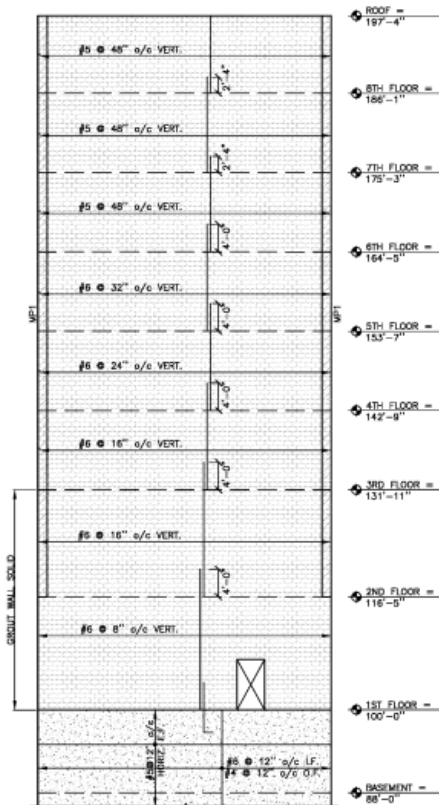

Figure 9 Masonry Shear Wall (S10.3 Drawing 2)

MASONRY PIER SCHEDULE					
MARK	TYPE	SIZE (L) IN INCHES	VERTICAL REINFORCEMENT (NOTE 2)	TIES	REMARKS
MP1	"A"	16	(2) - #5 BARS		
MP2	"A"	24	(3) - #5 BARS		
MP3	"A"	32	(4) - #5 BARS		
MP4	"A"	16	(2) - #5 BARS	NOTE (3), (8) #2 @ 8" o/c	
MP5	"A"	24	(3) - #5 BARS	NOTE (3), (8) #2 @ 8" o/c	
MP6	"A"	48	(6) - #5 BARS	NOTE (3), (8) #2 @ 8" o/c	
MP7	"C"	16 x 16	(3) - #5 BARS		
MP8	"C"	24 x 24	(5) - #5 BARS		
MP9	"A"	40	(5) - #5 BARS	NOTE (3), (8) #2 @ 8" o/c	
MP10	"D"	16 x 16	(4) - #5 BARS	NOTE (6) #3 TIES @ 16" o/c	

Figure 10 Masonry Pier Schedule (S13.3)

The size of vertical reinforcement for the masonry shear walls vary from #5 to #8. The spacing of the reinforcements also vary from 8” to 48” o.c. as the placement of reinforcing become higher in elevation. #5 bars, which is used the most throughout the shear walls, have 2’-4” of splice and #6 bars have 4’-0” splice.

Another lateral force resisting system is reinforced concrete shear walls that erect from the foundation and up to first and second level of the hotel structure. Varying from 12” to 14” thick, the concrete shear walls are vertically reinforced in two curtains with #5 or #6 for walls from

basement to first floor and #7 for walls from basement to second floor with varying spacing from 12” to 16” o.c. The horizontal reinforcement uses #5 or #6 bars both at 10” o.c. spacing.

The last lateral force resisting system is steel moment frame. Due to the demand and purpose of certain spaces that require spacious area, reinforced concrete and masonry shear walls were not adequate. Therefore, to remove the abruptness of blocking space from solid shear walls, steel moment frames were chosen. Due to this transition, the load from the masonry shear wall will transfer to the moment frame, which will have an impact on the lateral system analysis. The spaces which required these moment frames are the theme shop located in the basement level, service area such as reception, massage, relaxation rooms on second floor, and deluxe suite located on eighth floor.

The most influential space out of these three is the service area. While the other two spaces only require moment frame that replaces half of shear walls in one grid line, the service area has entire gridline to have moment frame as illustrated in figure 11. The frame uses smallest beam of W27x102 to biggest size of W36x330. The columns of the moment frame vary from W12x65 to W14x120.

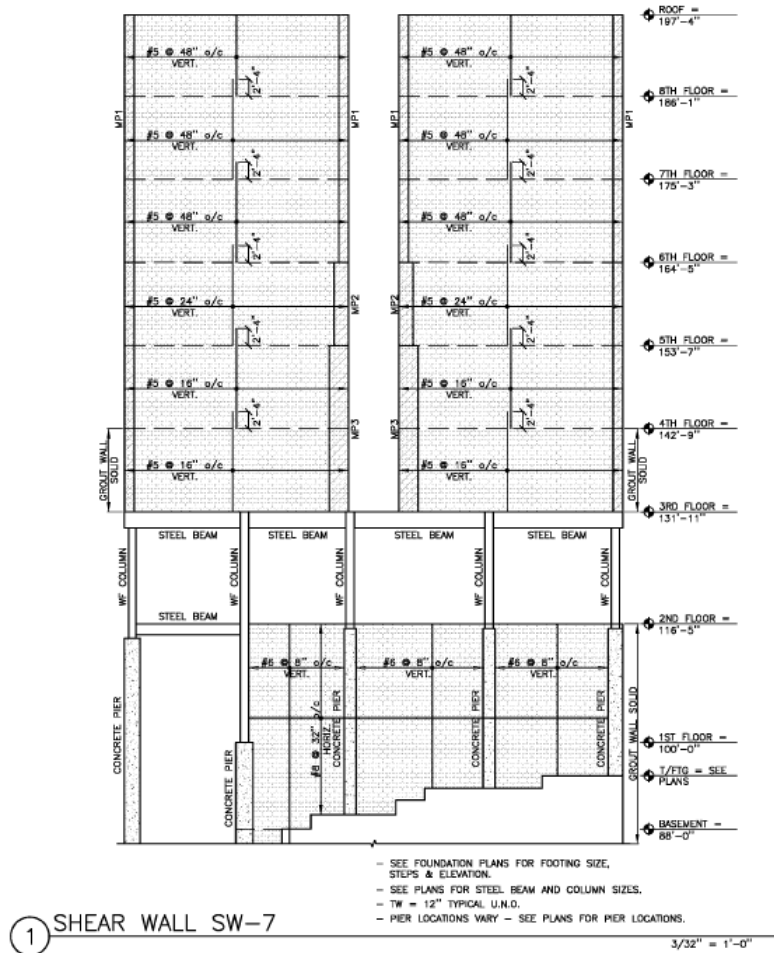

Figure 11 Shear Wall with Steel Moment Frames (S10.2 Drawing 1)

## Framing System

As described above, the structure is mostly comprised of 10” or 12” precast plank supported by masonry loadbearing shear walls oriented in one direction. The shear walls use 12x8x16 blocks fully grouted. While this framing system is dominantly present in this project, there are steel moment frame systems in some portion of the structure as described above section of this report.

### Typical Bay

The most replicated typical bay can be found in fourth floor layout, figure 12. This 69’ by 28’ bay is used from fourth floor to eighth floor. Due to precast planks forming stable frame system with masonry shear walls only in one direction, any need of beam spanning in the direction that is perpendicular of shear walls was eliminated; therefore, resulting such large typical bay.

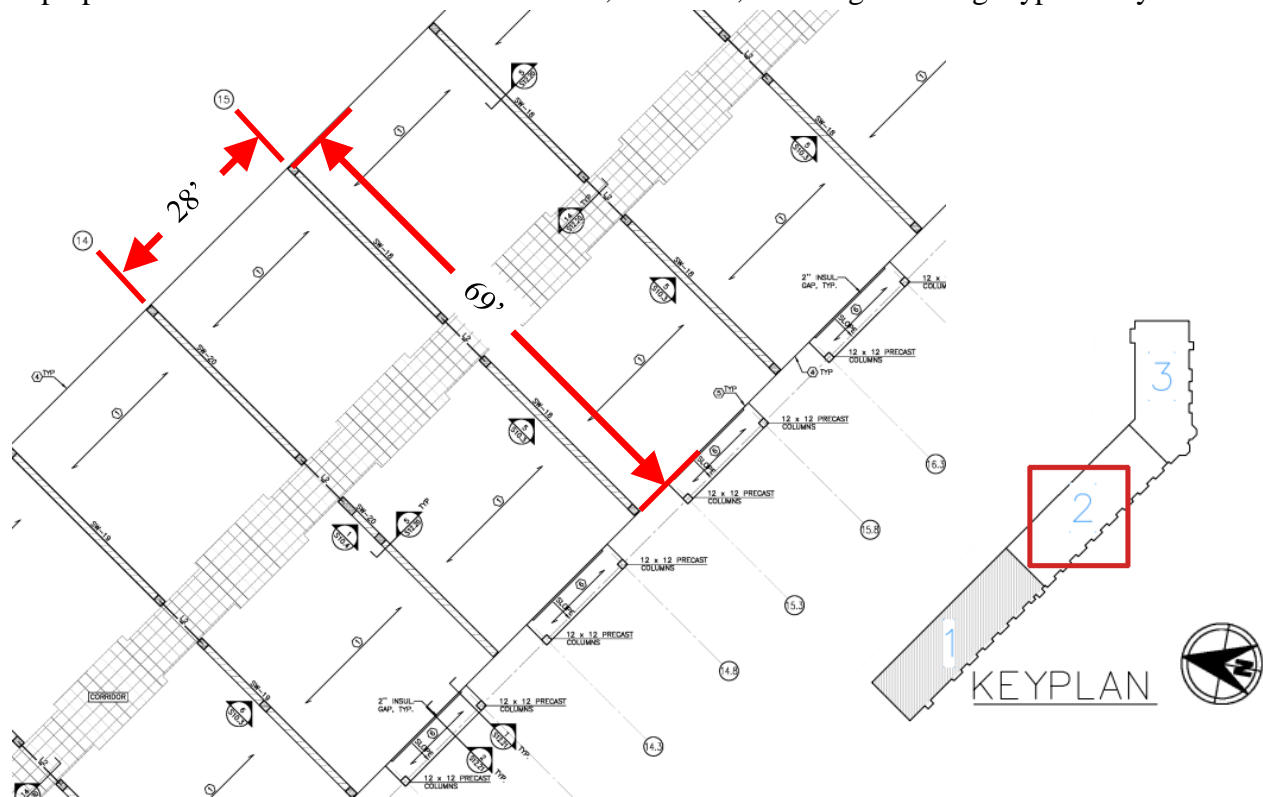
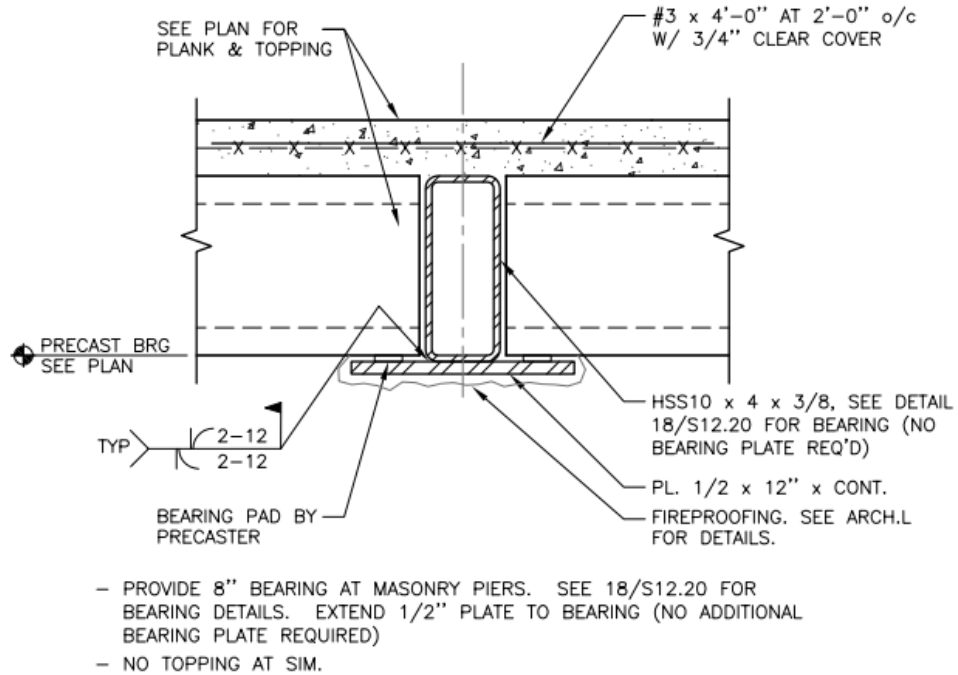

Figure 12 Typical Bay of Fourth Floor Plan (S4.2)

The 12” fully grouted masonry loadbearing shear walls with vertical reinforcement size of #5 with varying spacing per level are supporting 10” prestressed precast hollow core planks with 3” topping and bearing of 5.5”. These planks have 1 hour fire rating.

To leave the opening for the corridor but to not disrupt supporting planks, lintel system which consists of HSS 10x4x3/8 and steel plate of 1/2" deep and 12" wide is placed in between the two shear walls adjacent to the corridor, bearing 4" into the shear walls. As shown in figure 13, this lintel allows the precast planks to be supported, leaving an opening beneath.



14 TYPICAL CORRIDOR LINTEL DETAIL

Figure 13 Typical Corridor Lintel Detail (S12.20)

## Columns

Concrete piers were majorly used in basement and first level only where steel columns are located in order to support them. These concrete piers are in great number of various sizes. It ranges from a maximum size of 2' by 3'-4" to a minimum size of 16" by 16", shown below in figure 14. The steel columns that sits on top of concrete pier or right above foundation slab on grade have great number of varieties as well. To a minimum size of W10x49 to maximum of W14x120.

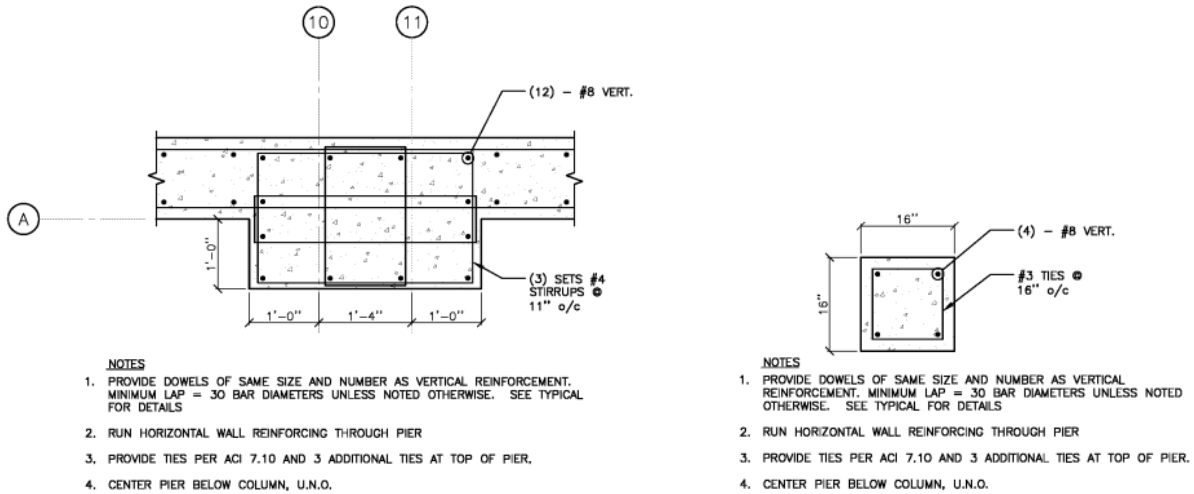

Figure 14 Concrete Piers (S12.02 Drawing 2 and 19)

There are also 12"x12" precast concrete columns that are supporting the balconies. Another interesting feature in columns from this structure is the canopy to support small roof that sheds an emergency exit, shown below in figure 15.

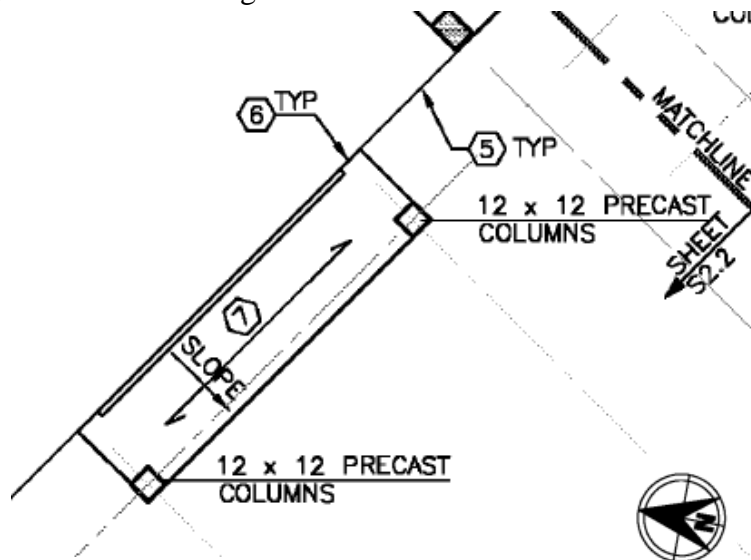

Figure 15 Typical Balcony Layout (S4.2)

## Roofing System

Roofing uses exactly the same 10” and 12” thick precast planks at the same locations as floors below but except without toppings. As can be seen in figure 16, 6” galvanized lightgauge metal stud parapet is connected by galvanized steel angle beam L4x4x3/8. There are also roofing above balconies (only on eighth floor) and entrances/exits. These hip roofs are supported by light steel trusses at 24” o.c.

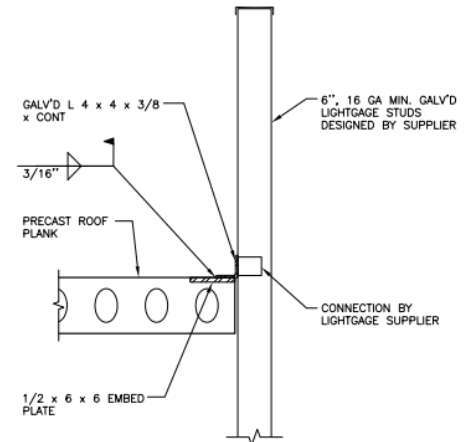

Figure 16 Typical Parapet Section (S12.30 Drawing 11)

## Joint Details

As previously described, the precast planks bears on top of shear walls that are topped with masonry bond beams and sits on bearing strips (figure 19). The planks that are connected to the wide flange beams are set on top of weld anchor finished with grouted butt joint, shown in figure 18 below. Precast planks supported by steel column will be connected by steel angle with stiffener plate in its center, shown in figure 17.

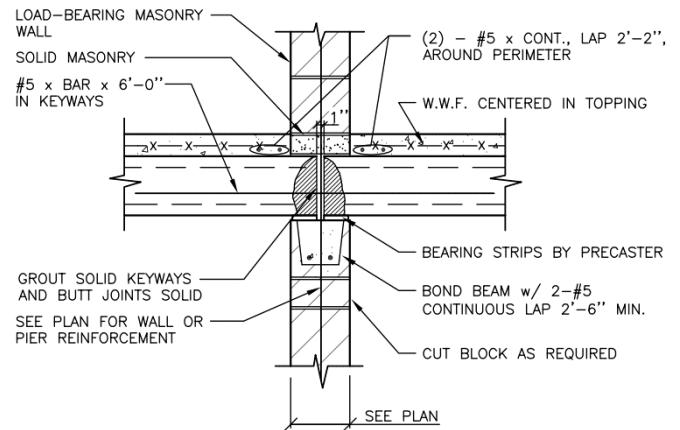

Figure 19 Precast Plank Bearing on Masonry Shear Wall (S12.20 Drawing 10)

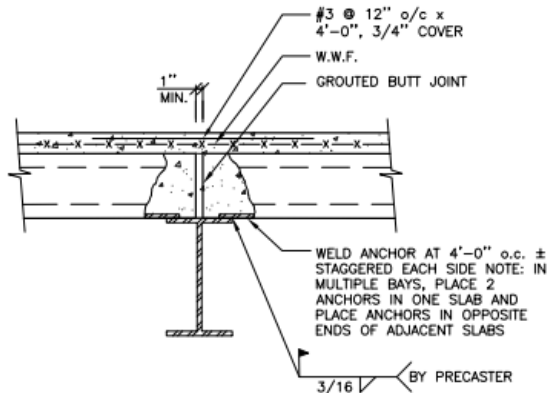

Figure 17 Precast Plank Bearing on Steel Beam (S12.20 Drawing 11)

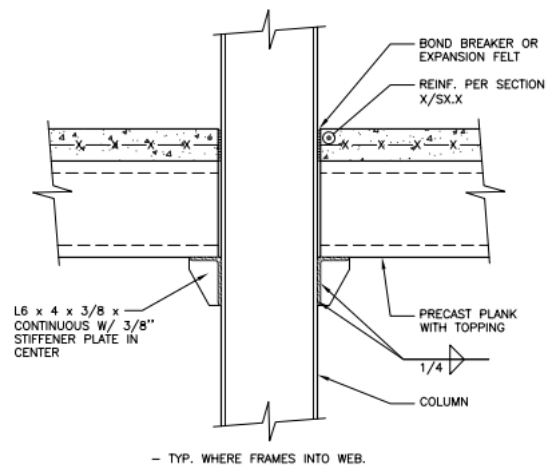

Figure 18 Precast Plank Support at Steel Column (S12.20 Drawing 8)



The typical steel framing section is as shown in figure 21. The column web holds double angle connection as well as clip angle to support wide flange beams. A typical steel moment connection shown in figure 20 has welded double angle connection with erection bolts.

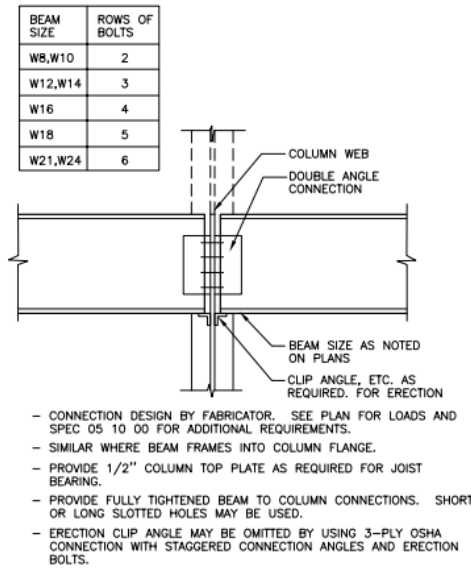

Figure 21 Typical Steel Framing Section

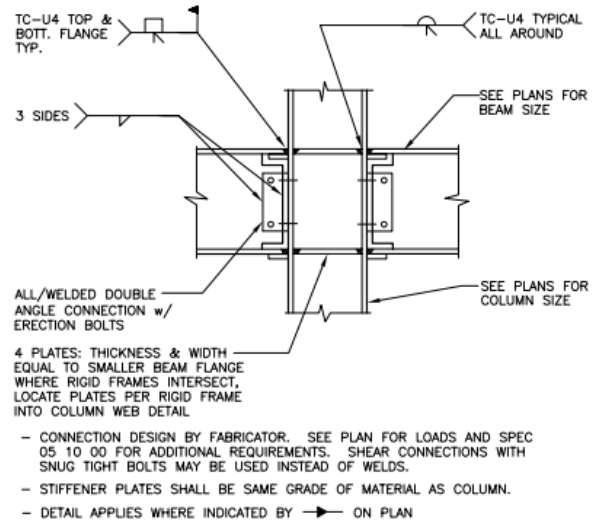
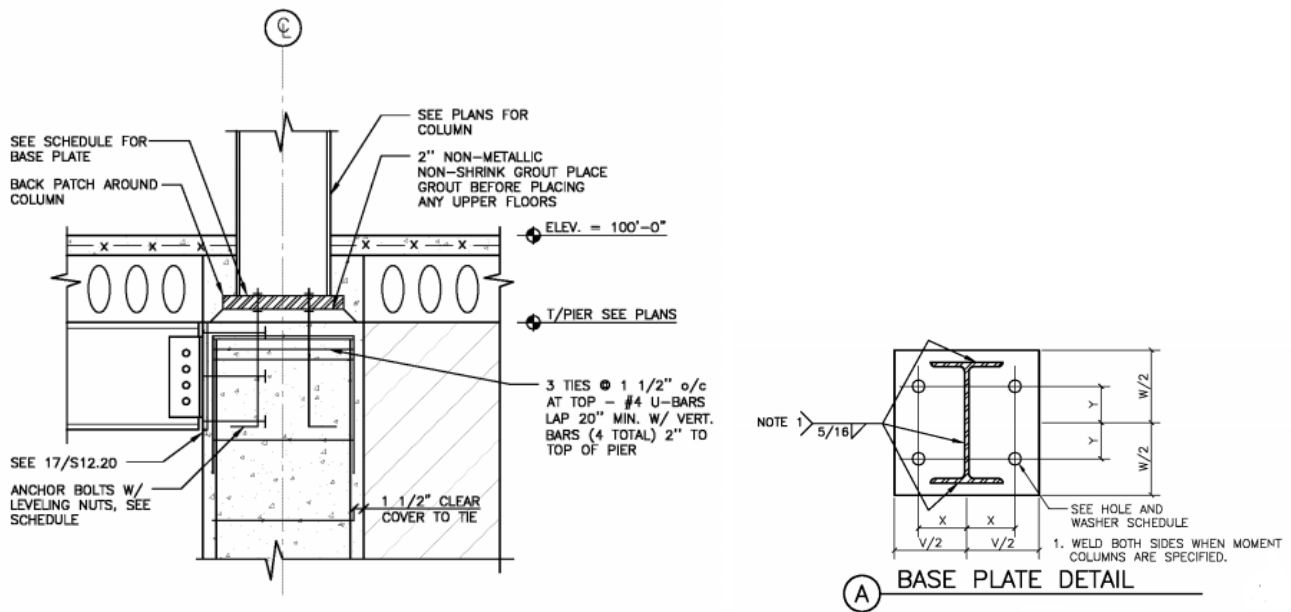

Figure 20 Typical Moment Connection

The steel column is connected to the baseplate shown in figure 22 with non-shrink grout that is injected between the baseplate and concrete pier. The anchor bolts with leveling nuts are installed under the base plate to level the baseplate prior to grouting.



10 STEEL COLUMN ON CONCRETE PIER  
3/4" = 1'-0"

Figure 22 Steel Column on Concrete Pier and Base Plate Detail (S12.22 Drawing 10, S13.3 Drawing A)

## Problem Statement

---

The existing hotel structure of Hakuna Resort contains total of 39 load bearing masonry shear walls. Considering the location of the project is not a highly active seismic area, this is too many shear walls. According to analysis done in Technical Report 4, the load bearing masonry shear walls do not require as much reinforcements documented in the original design due to the number of shear walls. Based on this information, it is determined that the original design is overly conservative and not cost efficient.

## Proposed Solution

To compare the efficiency of existing lateral system in terms of conservative design and cost, an alternate lateral system design with staggered steel truss system will be investigated and designed. By the nature of staggered truss system, the number of walls created by truss will be greatly reduced compared to the number of existing load bearing masonry shear walls. This solution will keep the original prestressed precast hollow core planks as floor system and replace gravity and lateral system to staggered truss system.

## Breadth Studies

### Architecture

The implementation of staggered steel truss system may have a big impact on floor plan layout in lower levels which includes public service areas that require open spaces. The existing structure handled this problem by using steel moment frame. The second floor contains vestibule, sauna, reception, relaxation rooms and massage treatment rooms, which does not follow the typical bay grid layout of hotel rooms above 3<sup>rd</sup> floor. Hence the floor plans of first and second levels need to be redesigned. The floor plans of 3<sup>rd</sup> level and above will remain the same to the original design to avoid any major conflict.

The exterior façade will also be redesigned to be more attractive and exciting. The existing façade follows brown color scheme to emulate earth, wood and nature, which resulted rather blend façade. By adding more variety of colors added with a pattern that resembles a tribal symbols as architectural finishes on the façade, the building will draw more excitement when families encounter the resort.

### Construction Management

The change in material of lateral system will result change in cost analysis including material cost and labor cost. Also, because it is a totally different system, it will have different assembly sequence which affects the schedule of project. In addition, any changes made in floor and façade redesign will be considered in terms of cost and schedule. After examination, these cost

and schedule data of staggered truss system will be compared to the existing lateral system to determine efficiency of each design.

## Solution Method

The first step before redesign of staggered truss system is to research and gather much knowledge as possible to be able to design the system. Majorly, the AISC Design Guide 14 Staggered Truss Framing Systems will be used in addition to other available documents related to the system. After the research and a couple of hand calculation, an ETABS model with the staggered truss system will be created and compared to the previous model created in Technical Report 4. These parameters include wind and seismic loads, story drifts and rigidity. During this redesign, the gravity and the lateral load resisting system will be calculated simultaneously.

Secondly, the new structural grid/layout may be implemented and the architectural layout will be redesigned accordingly. The floor plans of 3<sup>rd</sup> level and above, which contains hotel rooms, will remain the same as the original design. However, on the first and the second level which have service areas such as sauna, massage rooms and relaxation rooms. Unlike floors with hotel rooms, these service floors need to be more flexible. With the new staggered truss system placements, the floor plan of 1<sup>st</sup> and 2<sup>nd</sup> level will be redesigned by making the service rooms to fit in the staggered truss layout and have the least abruptness in the flow of the space.

The existing exterior façade of the hotel building was suggested to be rather blend in color for a water park resort. The current brown/grey color scheme will have additional variety of colors that will resemble jungle tribal pattern in order to bring exciting character to the building. The exterior architectural features will mostly remain the same as modern and simple façade but the finish panels will have more primary colors such as red, green and blue. Some portion of façade may have additional architectural features on the façade to accommodate the change in color to bring more excitement to the building.

Lastly, the cost of both lateral systems and architectural design changes will be analyzed using R.S. Means cost data by material cost and labor cost. The schedule of each system will be analyzed by the transportation of material, storage of material, and installation process. Then the efficiency of the new lateral system design with architectural design change will be compared to the original design based on its cost and schedule data.

## Tasks and Tools

- 1) Staggered Steel Truss Redesign
  - a. Research and investigate the system using AISC Design Guide 14 and other resources
  - b. Design gravity system
    - i. Size gravity columns and beams
    - ii. Check hollow core slab span
  - c. Design lateral system
    - i. Determine staggered truss locations
    - ii. Size truss members
    - iii. Create ETABS model
      1. Check for any error
    - iv. Check story drifts and deflections
    - v. Confirm validity of the model as necessary
    - vi. Evaluate member strength and serviceability
  - d. Compare redesigned lateral system to original
    - i. Check strength capacity of member in each system
    - ii. Check the base shear of each system
    - iii. Check and analyze the story drift
    - iv. Check the center of rigidity of each system
- 2) Architecture
  - a. Adjust floor plan layout according to truss placement
  - b. Redesign exterior façade
    - i. Choose different color to add
    - ii. Design finish panel patterns.
  - c. Create Sketches, Revit Model and renderings
- 3) Construction Management
  - a. Calculate a detailed cost analysis data for each system using R.S. Means.
  - b. Determine project schedule for each system
  - c. Compare the cost and schedule data and determine the efficiency of each system
    - i. Compare the performance of each lateral system
      1. Check controlling lateral loads
      2. Check deflections and story drifts
    - ii. Compare the cost of each system with respect to their performance above.
    - iii. Compare the impact of change in schedule when redesign is done.
      1. Will owner prefer the redesign?



## Conclusion

---

Through this report, the existing condition of structural system was explored as well as the problem statement with proposed solution was included for Hakuna Resort in Swiftwater, PA. The extraordinary number of load bearing masonry shear walls in the existing system raised a potential redesign opportunity of lateral system. To take the advantage of repetitive floorplan layout of hotel rooms, staggered steel truss system was chosen as alternate lateral system design.

The change of architectural features, such as floor layout of lower level and exterior façade, and construction management factors, such as cost and schedule, caused by the redesign will be analyzed and compared to the original system to determine the efficiency of both system and validate the best option.